



[www.ozb-usa.com](http://www.ozb-usa.com)

# AIRFILL

## ROUND BODY DUST COLLECTORS



TECHNICAL CATALOGUE  
ASSEMBLY-MAINTENANCE CATALOGUE  
SPARE PARTS CATALOGUE



OZB USA L.L.C.  
2513 Shallowford RD 200 Suite 310,  
Marietta GA, 30066

[www.ozb-usa.com](http://www.ozb-usa.com)  
[sales@ozb-usa.com](mailto:sales@ozb-usa.com)  
404-610-4334

All the products described in this catalogue are manufactured according to our quality system procedures.

This publication cancels and replaces any previous edition and revision. We reserve the right to implement modifications without notice. This catalogue can not be reproduced, even partially, without prior consent.

# Certificate

Standard **ISO 9001:2015**

Certificate Registr. No. **01 100 1815882**

# Certificate

Standard **ISO 14001:2015**

Certificate Registr. No. **01 104 1815882**

# Certificate

Standard **ISO 45001:2018**

Certificate Registr. No. **01 213 2115861**

## INDEX

<b>1.</b>	<b>TECHNICAL CATALOGUE</b>	<b>4</b>
1.1	BASIC SAFETY WARNINGS	5
1.2	SAFETY SYMBOLS	7
1.3	UNIT DESCRIPTIONS	7
1.4	OPERATION CONDITIONS	8
1.5	PRODUCT LABEL	8
1.6	PRODUCT CODE KEY	9
1.7	COMPOSITIONS	10
1.8	GENERAL DIMENSIONS	14
1.8.1	Flange Dimensions	15
1.9	TECHNICAL PROPERTIES	16
1.9.1	Standard Types	16
1.9.2	With Inspection Hatches	17
1.9.3	With Elliptical Bags	18
1.9.4	Cartridge Type Filter element	19
1.9.5	Bag Type Filter element	19
1.9.6	Bin for Dust Collection	19
1.9.7	Emission Sampling Kit	20
1.10	FAN	20
1.10.1	Fan Dimensions- On Filter	21
1.10.2	Fan Dimensions- Side Assembly on Seperate Frame	22
1.10.3	Fan Performance Table	23
1.11	PACKING DIMENSIONS AND WEIGHTS	23
<b>2.</b>	<b>ASSEMBLY-MAINTENANCE CATALOGUE</b>	<b>25</b>
2.1	SAFETY CONDITIONS AND PROTECTIONS	26
2.2	ASSEMBLY	28
2.2.1	Assembly of Fan On Filter	29
2.2.2	Side Assembly Fan on Seperate Frame	30
2.2.3	Assembly of Emission Sampling Kit	31
2.3	START UP	32
2.4	FILTER CONTROL BOARD	34
2.5	VALVE HEATER CARD	42
2.6	MAINTENANCE	44
2.7	LUBRICATION	46
2.8	REPLACEMENT OF COMPONENTS	46
2.8.1	Replcement of Cartridge	46
2.9	DEMOLITION	48
2.10	DEFINING PROBLEM AND TROUBLE SHOOTING	48
<b>3.</b>	<b>SPARE PARTS CATALOGUE</b>	<b>50</b>



[www.ozb-usa.com](http://www.ozb-usa.com)

1.

# TECHNICAL CATALOGUE



OZB USA L.L.C.  
2513 Shallowford RD 200 Suite 310,  
Marietta GA, 30066

[www.ozb-usa.com](http://www.ozb-usa.com)  
[sales@ozb-usa.com](mailto:sales@ozb-usa.com)  
404-610-4334

## 1.1 BASIC SAFETY WARNINGS

In compiling this instruction catalogue, careful attention has been paid to all considerations of operation and maintenance during normal working conditions. Buyers/users are exclusively responsible in complying all laws, rules and regulations in force in their country/area regarding safety of working environment and labour safety.

For matters which are not specified by the producer in this catalog, as requirements of the applicable environmental process, safety, health care and other social responsibilities applicable laws, regulations, instructions and rules will be effective.

Special care should be taken against all possible risks, danger and accidental incidents which may occur during the operation of the product.

This catalogue contains description and recommendations for to guide set-up, start-up, operation and maintenance procedures.

This catalogue or its related parts should be kept close to the product with easy access for users. It is the buyer's/user's responsibility and authority to ensure the delivery of this catalogue to related users of the product.

Never start any operation before reading this catalogue completely. The product is produced solely for its intended use. Please ask for producer's approval for different applications.

The product shall be operated in and under normal operating conditions. Producer is absolutely not responsible for any complications or their consequences in cases where alterations have been made without written consent of the producer.

All protective and safety clothes, tools, devices and conditions have to be supplied by user. The unit has to be fixed during and prior to any operation.

In order to perform assembly, maintenance, repair and cleaning on the product, according to 2006/42 EC the user must take all necessary precautions to ensure public safety, safety of the environment and it's entities and also take all actions to prevent any harm that may involve third parties.

Requirements of pneumatic lines and air usage shall be completed by the user to meet air consumption according to technical specifications which are given in technical catalogue.

Only fully qualified and authorized electricians should carry out electrical operations. Occupational safety and worker health requirements must be met. Electrical problems and their consequences are out of producers control and are not covered under warranty. The producer cannot be held responsible for any damages to property, persons or third parties, arising from poor electrical workmanship.

Always ensure that the power is disconnected before each operation. It is vital important that Power button has to be managed by a qualified person to prevent uncontrolled opening and closing.

All electrical connections shall be executed by the user to ensure safe operation. User also has to take necessary actions to avoid uncontrolled startup of machine by means of emergency stop and switches of sufficient amount.

Controlling the status of Voltage and frequency's compliance is important. The electrical earthing of the product must be proper, safety warnings should be clean and readable and all operations should be according to EN 600079-14 and TS 60204-1 EN standards.

Do not start up, if the unit is not complete and/or if not in proper condition. Do not interfere to the unit during operation. Never approach while the units are operating. Never let tools, hand or head to approach to the operating zone during operation.

If you should require further technical information or spares for your unit, please contact with producer and it is necessary to inform all datas such as serial number, type etc. which are written on the machine's plate.

Make sure that; all lifting/transportation operations must be carried out in accordance with the instructions specified in this catalog and the relevant standards. Lifting operations should be done with accessories and carrying systems suitable for unit dimensions and weight.

Producer can modify the product without notice and immediate effect. All dimensions specified in the catalog are for nominal standard parts. Dimensions and features may change depending on the type of project, applications, material.

This catalogue can not be changed without informing the producer. The latest version of the catalogue is accessible at our web site [www.ozb.com.tr](http://www.ozb.com.tr).

## 1.2 SAFETY SYMBOLS

These signs are of a warning nature and do not eliminate the risk. These instructions and/or warnings are recommendations, which should be run in conjunction with the latest health and safety directives in accident prevention.

<b>MAX PRESSURE 5 BAR</b>	 <b>MAX PRESSURE 5 BAR</b>
---------------------------	-----------------------------------------------------------------------------------------------------------------------

<b>WARNING DANGER</b> Special indication, provision and prohibiton to prevent injury to personnel.	
-------------------------------------------------------------------------------------------------------	---------------------------------------------------------------------------------------

<b>ELECTRICAL POWER DANGER</b>	
--------------------------------	---------------------------------------------------------------------------------------

### 1.3 UNIT DESCRIPTIONS

Filters are generally used to withhold particles from spreading during the transfer of a bulk solid to an enclosed stocking area.

AIRFILL brand filters provide a filtering area between 65 ft<sup>2</sup> to 387 ft<sup>2</sup> and are produced with body diameters of 16", 24", 31" and 39".

AIRFILL filters comprises of;

- Jet-pulse cleaning system
- Stainless steel body
- Cartridge, round bag and elliptical bag type filter elements
- External and easy-to-reach valves
- Easy-to-reach external control panel
- Stainless steel filter element plate
- Silo mounting flange as standard.

In addition;

- Stainless steel silo flanges,
- 0,75 kW (1.0 Hp) to 3 Kw (4.0 Hp) fan and
- Hopper units and bin for dust collection are available.

Model	Filtering Area (ft <sup>2</sup> )	Air Flow (cfm)	Dimensions		
			Diameter (in)	Height (Closed Lid) (in)	Height (Open Lid) (in)
HOPPERFILL 01	11	53	10	27	37
AIRFILL 06	65	318	16	37	51
AIRFILL 09	97	477	16	50	61
AIRFILL 12	129	636	24	35	54
AIRFILL 18	194	953	24	47	66
AIRFILL 25	269	1,324	31	33	66
AIRFILL 36	387	1,907	31	46	73
AIRFILL D18	194	953	31	50	61

### 1.4 OPERATION CONDITIONS

Products are not designed to operate at explosive, flammable, toxic, hazardous viral or bacterial dangerous environment and/or materials. If the machine has to operate in these conditions, the manufacturer must be informed.

The appropriate use of the unit according the food norms should be reported to the manufacturer at order although the unit has to be produced accordingly.

Max admissible temperatures

176°F Continuous  
212°F Intermittent/Instantaneous  
-4°F

Max pressure on construction;  
1000 mmH<sub>2</sub>O (1.42 psi) positive  
-400 mmH<sub>2</sub>O (-0.57 psi) negative

### 1.5 PRODUCT LABEL

Every unit is supplied with identification plates showing;

- Manufacturer's information
- Manufacturer's web site
- CE logo
- Product code
- Production place
- Type
- Serial number
- Production year
- Temperature
- Pressure

Do not throw away the labels on the unit and do not change the information on the label. Make sure that labels are clean and legible.



### 1.5 PRODUCT CODE KEY

1	2	3	4	5	6
AIRFILL	21	C	R	08	1.5

1	Unit Code	AIRFILL
2	Filtering surface	XX XX m <sup>2</sup>
3	Filter element type	C Cartridge
		B Round Bag
		E Elliptical Bag
4	Dust Collector type	S Standard
		N Vacuum
		R Filter element removable from inspection hatch
		I Insertable
5	Dust Collector body diameter	04 400 mm – 16"
		06 600 mm – 24"
		08 800 mm – 31"
		10 1000 mm – 39"
6	Fan motor power	0,75kw (1.0 Hp) – 3,0kw (4.0 Hp)

## 1.6 COMPOSITION

### 1.6.1 AIRFILL.06.C.S.04 AIRFILL.09.C.S.04

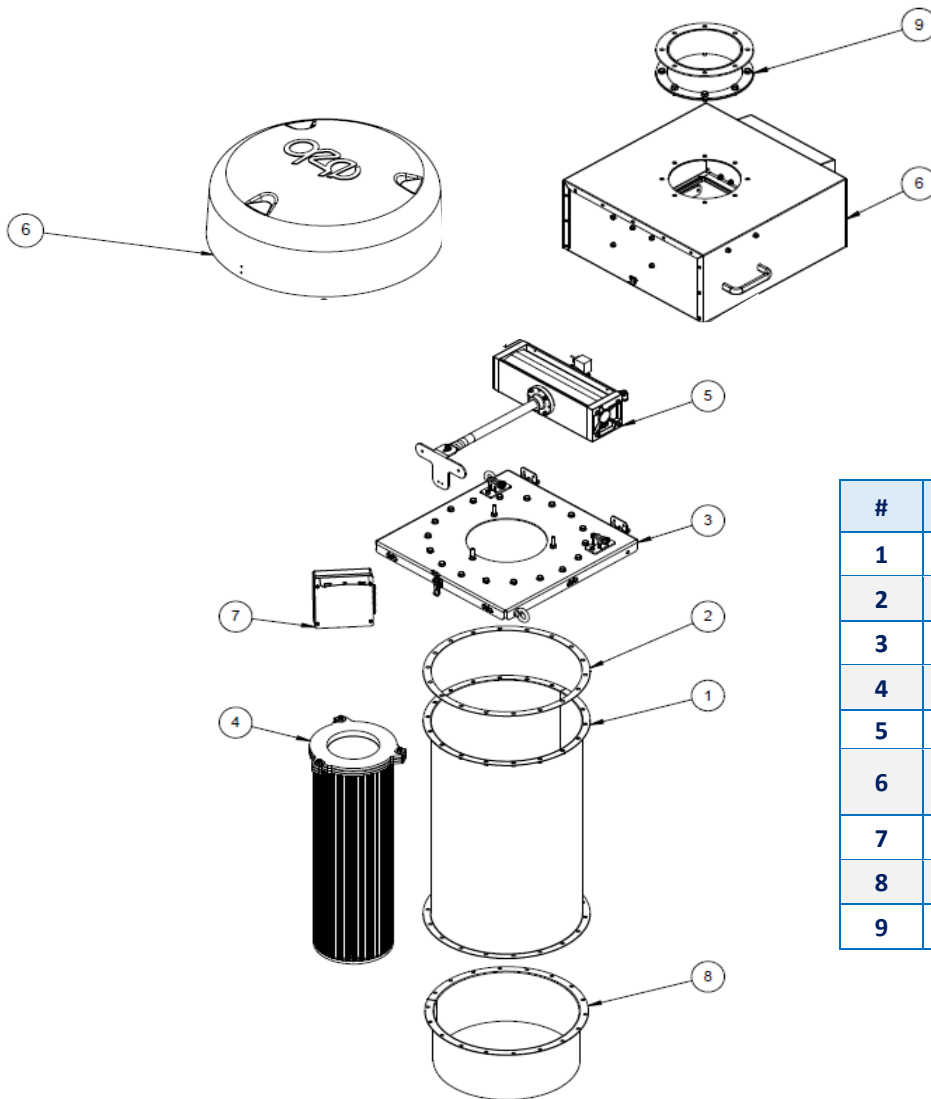

#	Description
1	Filter body
2	Seal
3	Filter element plate
4	Filter element
5	Air tank
6	a) Filter cover b) Filter cover with fan
7	Electronic card
8	Flange
9	Fan connection adaptor

**1.6.2 AIRFILL.12.C.S.06 & AIRFILL.18.C.S.06  
AIRFILL.25.C.S.08 & AIRFILL.36.C.S.08**

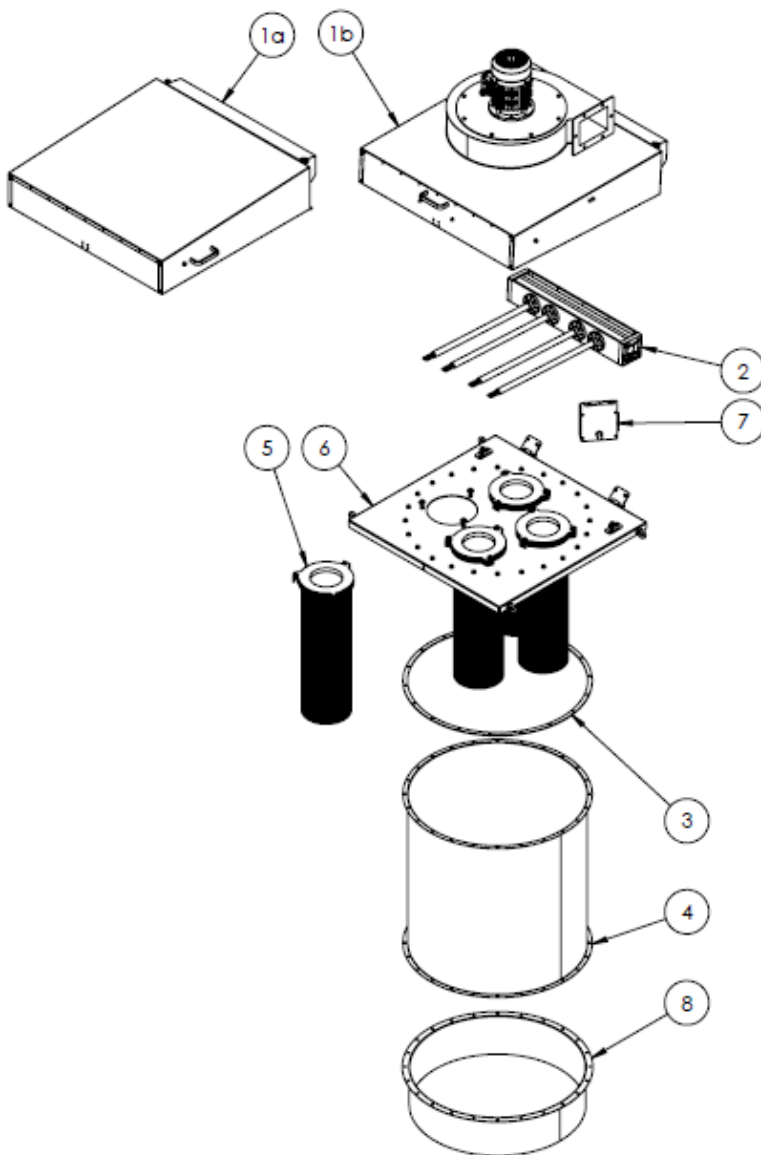

#	Description
1	a) Filter cover b) Filter cover with fan
2	Air tank
3	Seal
4	Filter body
5	Filter element
6	Filter element plate
7	Electronic card
8	Flange

**1.6.3 AIRFILL.12.C.R.08 & AIRFILL.21.C.R.08  
AIRFILL.06.B.R.08 & AIRFILL.10.B.R.08**

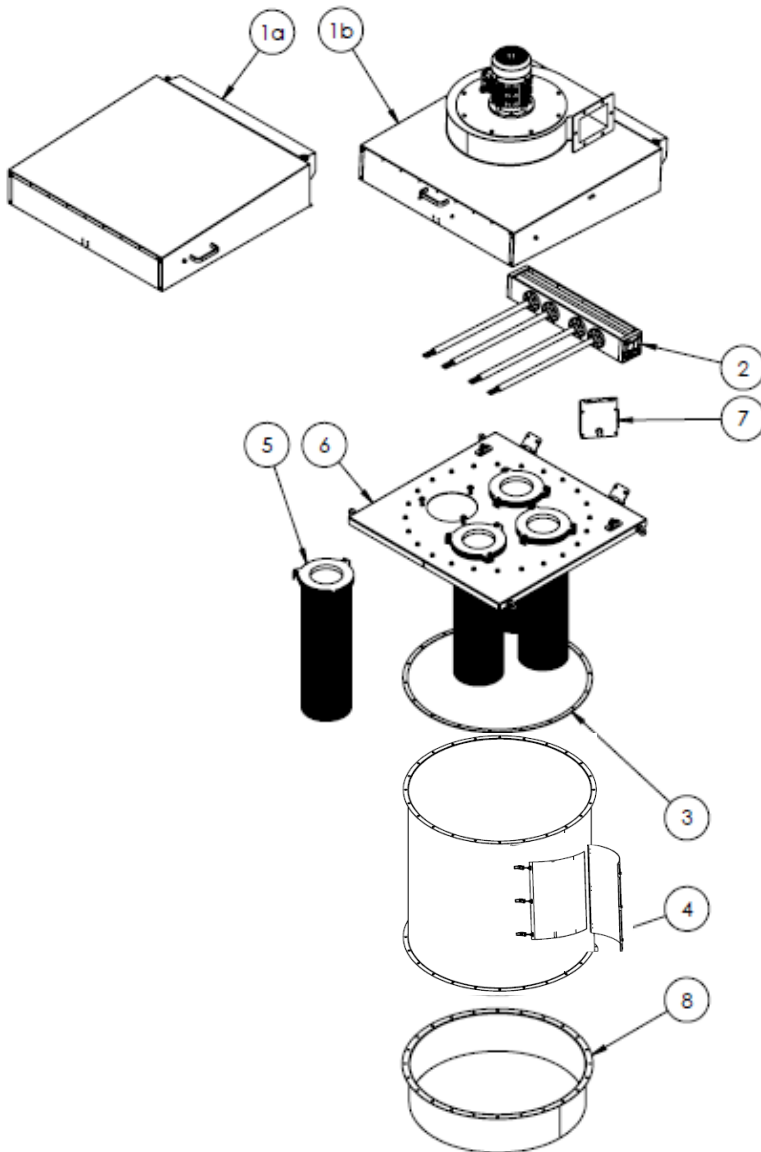

#	Description
1	a) Filter cover b) Filter cover with fan
2	Air tank
3	Seal
4	Filter body (with inspection hatch)
5	Filter element
6	Filter element plate
7	Electronic card
8	Flange

1.6.4 AIRFILL.10.E.S.08  
 AIRFILL.14.E.S.08  
 AIRFILL.28.E.S.10

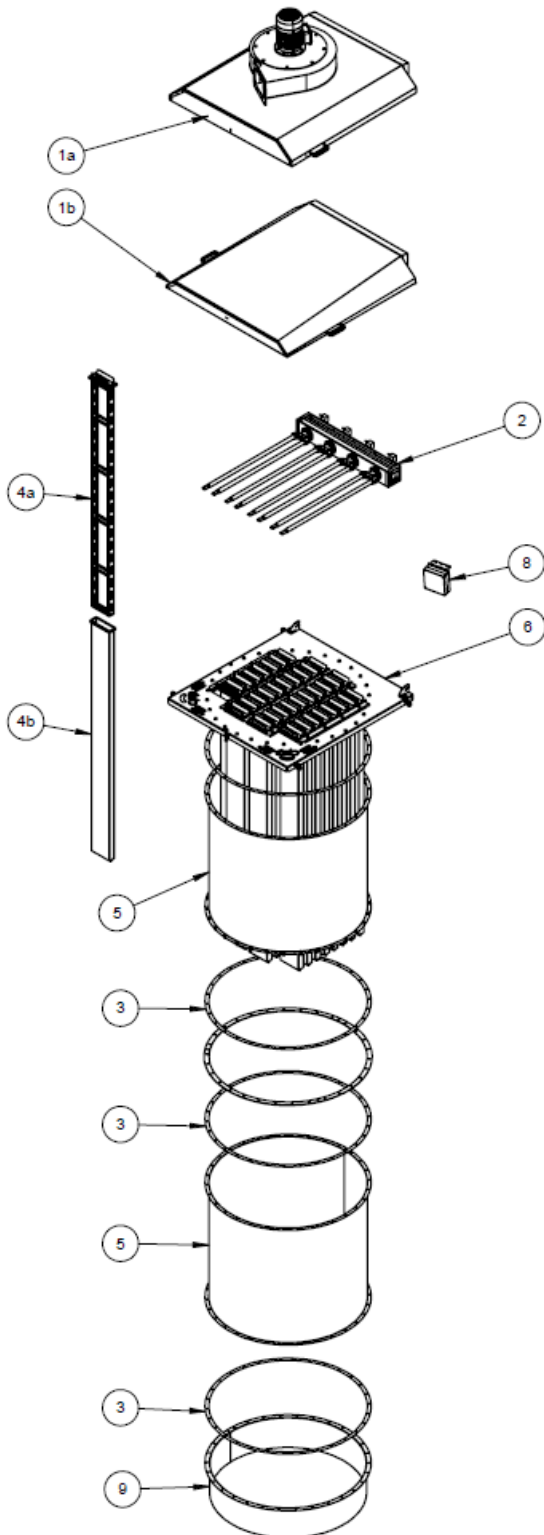

#	Description
1	a) Filter cover b) Filter cover with fan
2	Air tank
3	Seal
4	a) Cage b) Elliptical bag
5	Filter body
6	Filter element plate
7	Electronic card
8	Flange

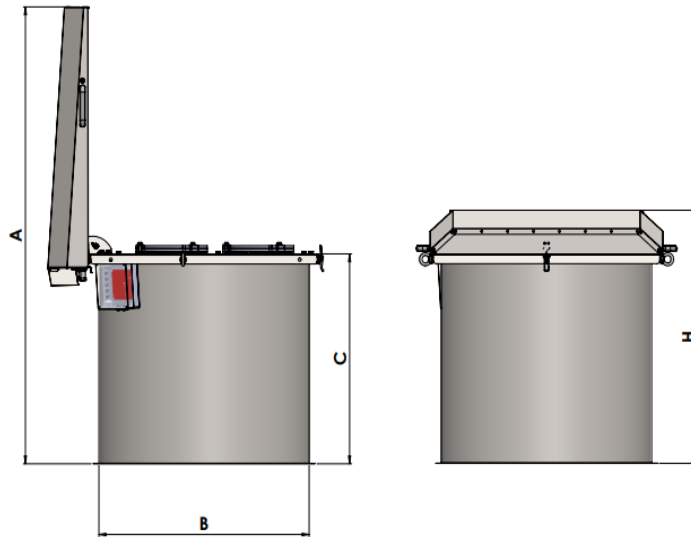

Type	A (in)	ØB (in)	C (in)	H (in)	Figure
AIRFILL.06.C.S.04.0	51	16	27	38	
AIRFILL.09.C.S.04.0	63	16	40	50	
AIRFILL.12.C.S.06.0	54	24	27	35	
AIRFILL.18.C.S.06.0	66	24	40	47	
AIRFILL.25.C.S.08.0	62	31	27	34	
AIRFILL.36.C.S.08.0	73	31	40	46	
AIRFILL.12.C.R.06.0	65	31	32	38	
AIRFILL.21.C.R.06.0	81	31	48	54	
AIRFILL.06.B.R.08.0	75	31	42	48	
AIRFILL.10.B.R.08.0	103	31	70	76	
AIRFILL.10.E.S.08.0	81	31	48	54	
AIRFILL.14.E.S.08.0	99	31	67	73	
AIRFILL.28.E.S.10.0	118	41	73	79	

### 1.8.5 FLANGE DIMENSIONS

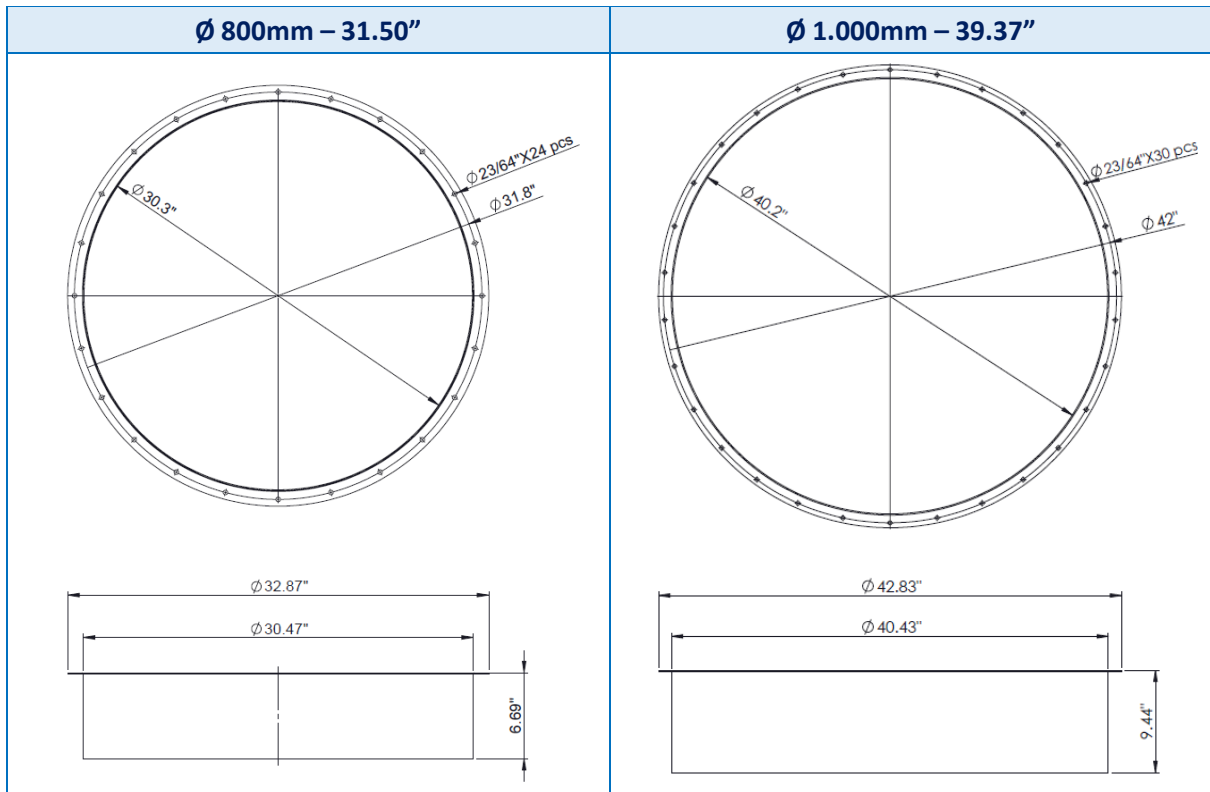
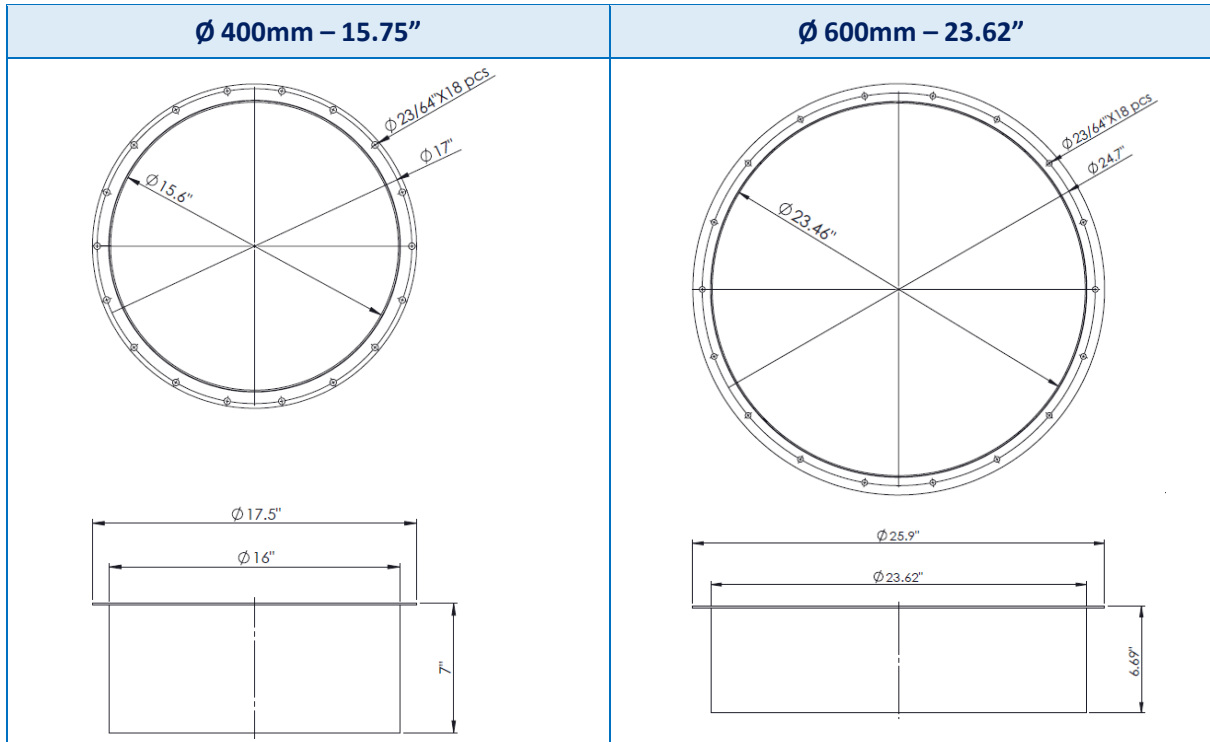

## 1.9 TECHNICAL PROPERTIES

### 1.9.1 AIRFILL STANDARD TYPES

Technical Specifications	AIRFILL 06 C.S.04.0	AIRFILL 09 C.S.04.0	AIRFILL 12 C.S.06.0	AIRFILL 18 C.S.06.0	AIRFILL 25 C.S.08.0	AIRFILL 36 C.S.08.0
Filtering area:	6 m <sup>2</sup> 64 ft <sup>2</sup>	9 m <sup>2</sup> 97 ft <sup>2</sup>	12 m <sup>2</sup> 129 ft <sup>2</sup>	18 m <sup>2</sup> 194 ft <sup>2</sup>	25 m <sup>2</sup> 269 ft <sup>2</sup>	36 m <sup>2</sup> 387 ft <sup>2</sup>
Body diameter:	400 mm – 16"		600 mm – 24"		800 mm -31"	
Body material:	Stainless steel					
Protection cover:	Thermoplastic		Paslanmaz çelik Stainless steel			
Filter element:	Ø 218 mm – 8.58" cartridge					
Filter element quantity:	1		2		4	
Filter element length:	700mm 28.56"	1.000mm 39.37"	700mm 28.56"	1.000mm 39.37"	700mm 28.56"	1.000mm 39.37"
Filtering media:	8 Oz - %100 polyester					
Filter element plate:	Stainless steel					
Cleaning system:	Jet pulse					
Electronic board:	Included					
Number of electrovalves:	1		2		4	
Silo connection flange:	Carbon steel					
Fan:	1 HP (0,75 kW) to 4 HP (3 kW) fan options					
Hopper:	Optional, made of galvanized or stainless steel					
Bin for dust collection	Optional, made of galvanized or stainless steel, nominal 9.25 gal					
Exhaust emission sampling kit:	Optional					

### 1.9.2 AIRFILL WITH INSPECTION HATCH TYPES

Technical Specifications	AIRFILL 12 C.R.08.0	AIRFILL 21 C.R.08.0	AIRFILL 06 B.R.08.0	AIRFILL 10 B.R.08.0
Filtering area:	12 m <sup>2</sup> 129 ft <sup>2</sup>	21 m <sup>2</sup> 226 ft <sup>2</sup>	6 m <sup>2</sup> 64 ft <sup>2</sup>	10 m <sup>2</sup> 107 ft <sup>2</sup>
Body diameter:	800 mm – 31”		800 mm – 31”	
Body material:	Stainless steel		Stainless steel	
Protection cover:	Stainless steel		Stainless steel	
Filter element:	Screwable cartridge removable form inspection hatch		Screwable round bag removable form inspection hatch	
Filter element quantity:	14	14	14	14
Filter element length:	600mm – 23.62”	1.000mm – 39.37”	1050mm – 41.34”	1.700mm – 66.93”
Filtering media:	8 Oz - %100 polyester		15.48-16.22 oz - %100 polyester	
Filter element plate:	Stainless steel		Stainless steel	
Cleaning system:	Jet pulse		Jet pulse	
Electronic board:	Included		Included	
Number of electrovalves:	4		4	
Silo connection flange:	Carbon steel		Carbon steel	

### 1.9.3 AIRFILL WITH ELLIPTICAL BAG TYPES

Technical Specifications	AIRFILL 10 E.S.08.0	AIRFILL 14 E.S.08.0	AIRFILL 28 E.S.10.0
Filtering area:	10 m <sup>2</sup> 107 ft <sup>2</sup>	14 m <sup>2</sup> 150 ft <sup>2</sup>	28 m <sup>2</sup> 310 ft <sup>2</sup>
Body diameter:	800 mm – 31”		1000 mm – 39”
Body material:	Stainless steel		
Protection cover:	Stainless steel		
Filter element:	Elliptical bag		
Filter element quantity:	20	20	36
Filter element length:	1200	1.600	1800
Filtering media:	15.48-16.22 oz - %100 polyester		
Filter element plate:	Paslanmaz çelik Stainless steel		
Cleaning system:	Jet pulse		
Electronic board:	Included		
Number of electrovalves:	3	3	4
Silo connection flange:	Carbon steel		

#### 1.9.4 CARTRIDGE TYPE FILTER ELEMENT

Composition	100% Spunbonded Polyester
Weight	7.96 oz/yd <sup>2</sup>
Thickness	0.6 mm – 0.02”
Tensile strength md	1200 N/5cm – 0.24 MPa
Tensile strength cd	600 N/5cm – 0.12 MPa
Elongation md	40%
Elongation cd	30%
Permeability to air	560cfm
Volume of pores	66%
BIA rating	M
Color	White

#### 1.9.5 BAG TYPE FILTER ELEMENT

100% Polyester + Antafin empregnado, 525-550g/m<sup>2</sup>, resistencia to water, humidity and oil.

#### 1.9.6 BIN FOR DUST COLLECTION

It is possible to supply dust collection bin at the exit of the hopper. It has a nominal volume of 35 lt and is produced as galvanized as standard, stainless steel option is also available upon request. Bin for dust collection can be mounted under the hopper with BV1F250 single flanged butterfly valve and flexible bellows.

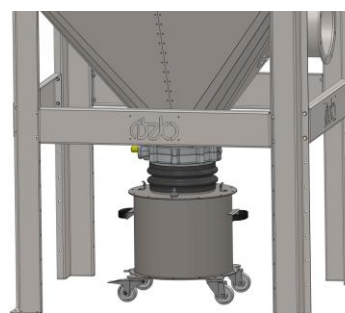
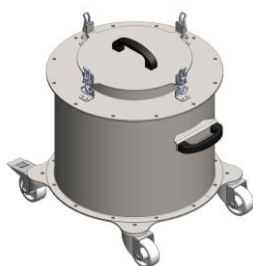

### 1.9.7 EMISSION SAMPLING KIT

Emission sampling kit for AIRFILL Filters is available as an option. The kit includes 1 blind flange, 1 flanged exhaust pipe and connection bolts. The vertical exhaust discharge pipe to be mounted on the flanged exhaust pipe must be supplied by the user.

#### AIRFILL 12 & AIRFILL 18 & AIRFILL 25 & AIRFILL 36

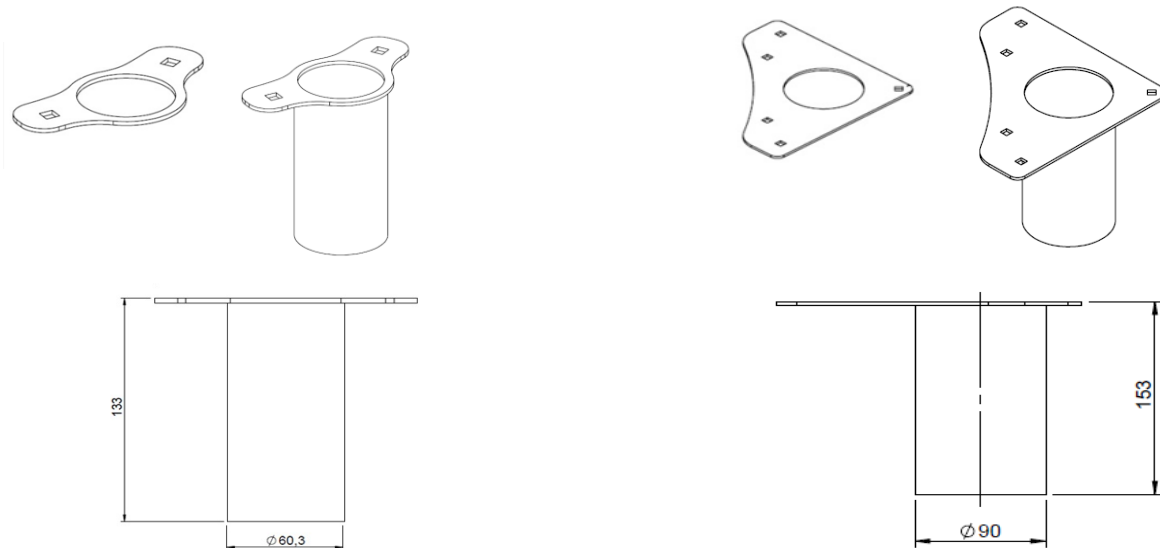

### 1.10 FAN

Fan applications are used for directing dust in the air towards the filter and holding the dust on the filter element during its passage and discharging clean air into the atmosphere.

Fans can be used either on top of the filter or on the side with a frame. In both applications, if the fan aspiration is too high, it is possible to decrease the flow (filtering speed) by closing the fan outlet.

Fan is separately supplied. And always disassemble fan during transport, never assemble the fan before the filter is rigidly fixed to the frame. For long term operation for any kind, ensure that the fan is disassembled and kept in another base.

In cases where the fan is mounted on the filter; the inspection on filtering elements may be done by simply lifting the filter cover, thanks to the innovative design by OZB. This innovation provides economy of operation and reduced initial investment.

Maintenance, however, shall be done at limited positions and in order to make a safe maintenance operation, the fan needs to be disassembled.

Please kindly note that; the fan and cover can easily be opened. Always make sure that the locking arms are locked when the cover is open. Do not open the cover if fan and filter unit is fixed to location. Of the duration of operation is longer than 3-5 minutes, please add separate stopper.

Do not open the cover in open and windy areas. Ensure that all related regulations in force in the area use about labor environment and safety are by user.

### 1.10.1 FAN DIMENSIONS (Mounted on Dust Collector)

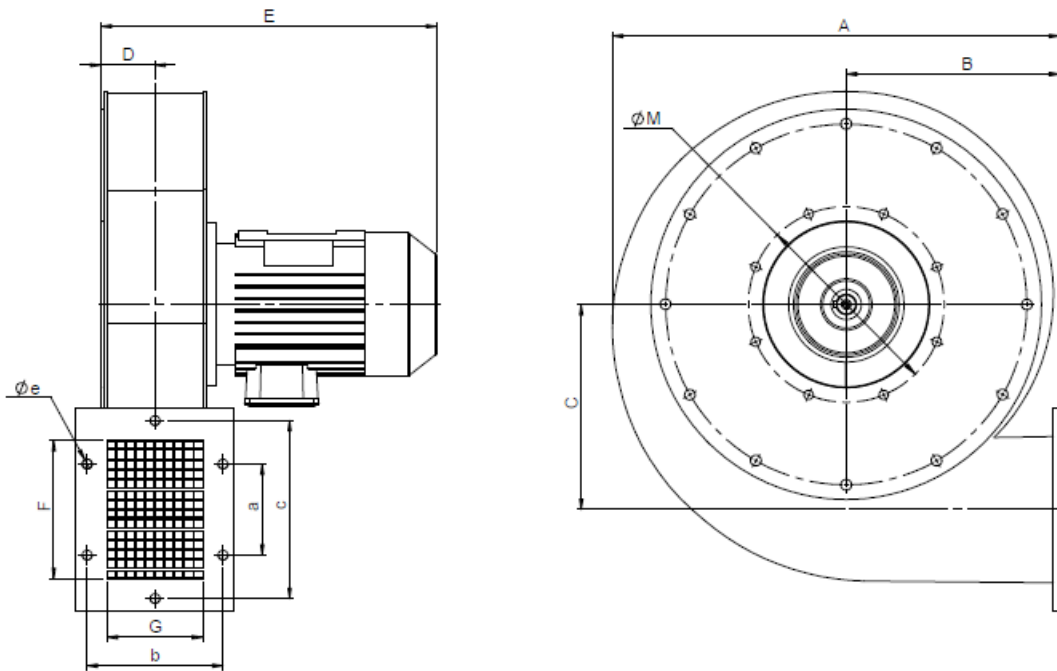

Fan Motor Power	A (in)	B (in)	C (in)	D (in)	E (in)	F (in)	G (in)	a (in)	b (in)	c (in)	Ø e (in)
1 HP	16.54	7.87	07.09	2.28	13.98	5.91	4.33	4.41	06.02	7.87	0.47
1.5 HP	18.19	8.66	8.27	2.28	13.98	5.91	4.33	4.41	06.02	7.87	0.47
2 HP	19.69	9.45	8.82	2.56	14.57	6.69	4.72	4.41	6.57	8.62	0.47
2.7 HP	21.65	10.24	10.00	2.56	16.34	6.69	4.72	4.41	6.57	8.62	0.47

### 1.10.2 FAN DIMENSIONS (Mounted on separate frame)

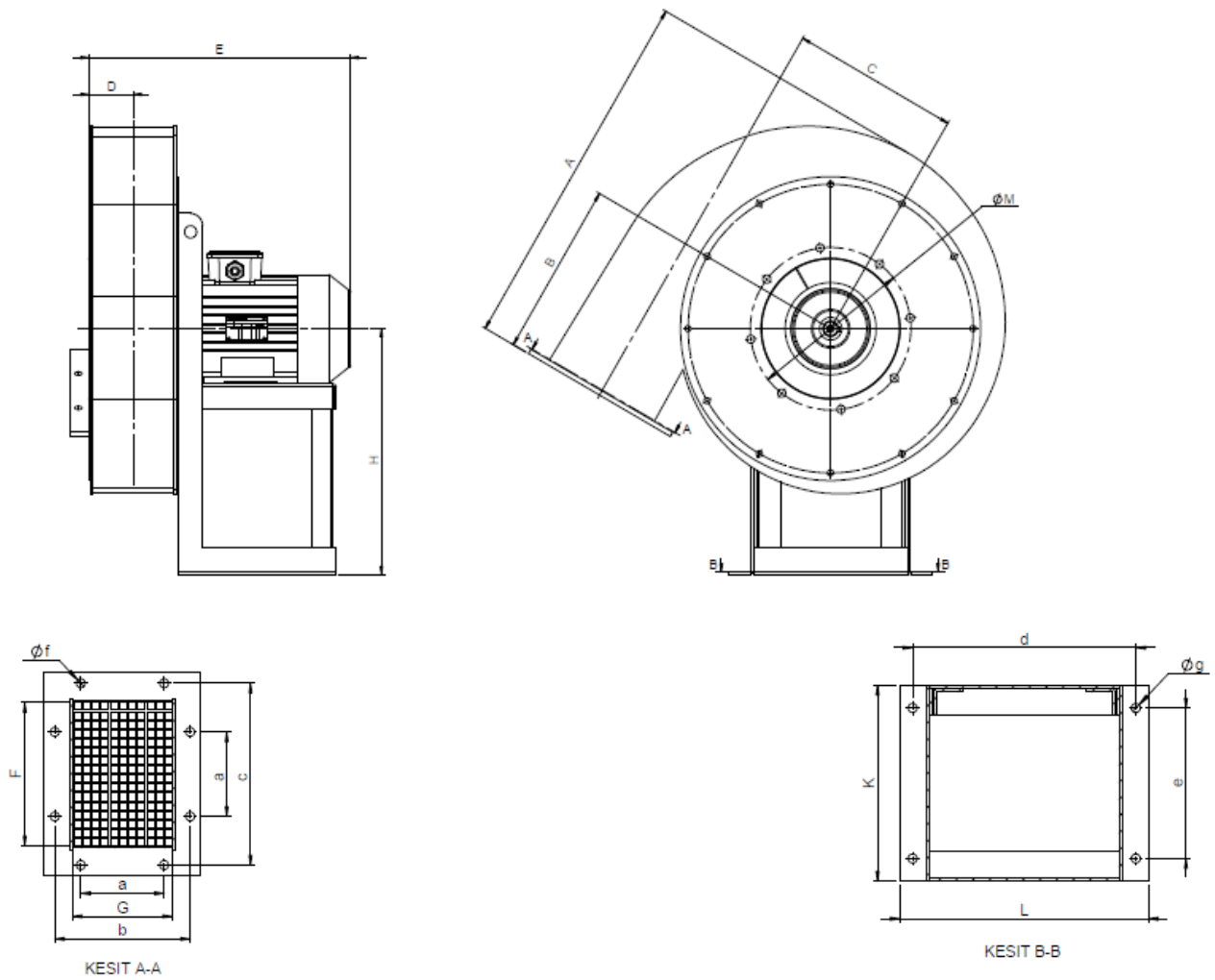

Fan Motor Power	A (in)	B (in)	C (in)	D (in)	E (in)	F (in)	G (in)	H (in)	K (in)	L (in)	a (in)	b (in)	c (in)	d (in)	e (in)	$\phi f$ (in)	$\phi g$ (in)
2.7 HP	22.83	11.18	14.76	2.87	16.93	7.48	5.51	15.75	10.24	13.19	4.41	7.17	9.49	11.81	7.87	0.47	0.47
4 HP	25.51	12.20	12.01	2.87	18.23	7.48	5.51	15.75	10.24	13.19	4.41	7.17	9.49	11.81	7.87	0.47	0.47

### 1.10.3 FAN PERFORMANCE TABLE

Fan Motor Power	Revolution (rpm)	Max Air Capacity (cfm)	Max Pressure (psi)
1 HP	3000	1,295	0.28
1.5 HP	3000	1,648	0.33
2 HP	3000	1,942	0.40
3 HP	3000	2,236	0.48
4HP	3000	2,648	0.58

Fan Motor Power	Pressure (psi)	0	0.15	0.22	0.29	0.36	0.44	0.51
1 HP	Air Capacity (cfm)	1,295	912	677				
1.5 HP		1,648	1,265	1,118	735			
2 HP		1,942	1,589	1,354	1,118	706		
3 HP		2,237	1,883	1,707	1,530	1,236	883	
4HP		2,649	2,413	2,207	2,001	1,765	1,589	1,295

### 1.11 PACKAGING DIMENSIONS AND WEIGHTS

Package sizes and weights of the units are given below.

When receiving the units; check if the unit code and quantity are compatible with your order. Possible damages must be reported/informed to the authorized person of cargo/transportation company before taking the goods. The manufacturer is not responsible for any damage that may occur during transportation.

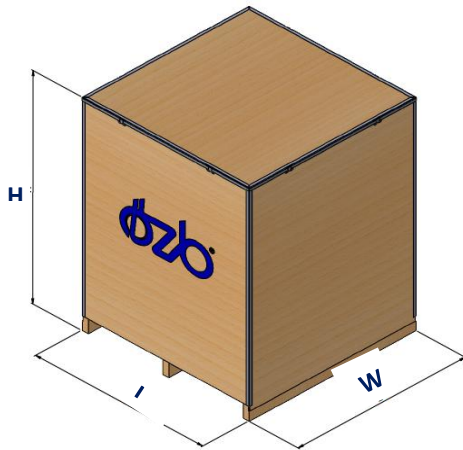

Dust Collector Type	L (in)	W (in)	H (in)	Net Weight (lbs)	Gros Weight (lbs)
AIRFILL.06.C.S.04.C.0	27.56	27.56	38.19	70.99	99.21
AIRFILL.09.C.S.04.C.0	27.56	27.56	51.18	75.18	101.63
AIRFILL.12.C.S.06.C.0	33.46	33.46	37.40	141.09	168.65
AIRFILL.18.C.S.06.C.0	33.46	33.46	49.21	176.37	220.46
AIRFILL.25.C.S.08.C.0	40.55	40.55	35.83	214.51	246.92
AIRFILL.36.C.S.08.C.0	40.55	40.55	51.57	220.46	277.78

Fan Type	L (in)	W (in)	H (in)	Net Weight (lbs)	Gros Weight (lbs)
1 HP	25.59	21.65	15.75	61.7	63.9
2 HP	7.56	23.62	17.72	92.6	97.0
3 hp	7.56	23.62	17.72	103.6	108.0



## 2.

# ASSEMBLY-MAINTENANCE CATALOGUE

## 2.1 SAFETY CONDITIONS AND PROTECTIONS

It needs to be kept at nearest position available for the concerned personnel for installation, operation, maintenance and repair staff.

This catalogue is a guide for users. It is the user's responsibility to take all necessary precautions to ensure occupational safety, worker health and safety of third parties as well as ensuring operations in accordance with local laws and regulations.

In order to perform assembly, maintenance, repair and cleaning on the product, according to 2006/42/EU, 2004/108/EU, 2006/95/EU Directives the user must take all necessary precautions to ensure public safety, safety of the environment and it's entities and also take all actions to prevent any harm that may involve third parties.

In case of handling hot material over 60°C, it is the user's responsibility to assemble barriers and warnings in order to secure the work place.

Apart from normal operating conditions, the product has to be in safe position.

This unit may be working on dynamic forces, electrical energy and pressurized air and operates under high level of mechanical risk. Accidents that may arise due to any of the above or any combination of the above may result in catastrophic effects. Therefore, the user is responsible to supply maximum security in all stages and operations.

All related staff should be trained, authorised and specialised. For all work to be done on the product, other than normal operation, the electrical connection must be cut, all movement stopped, pressurised air supply disconnected and the product must be in good condition and in park mode.

Only fully qualified and authorized electricians should carry out electrical operations. Occupational safety and worker health requirements must be met. Electrical problems and their consequences are out of producers control and are not covered under warranty. The producer cannot be held responsible for any damages to property, persons or third parties, arising from poor electrical workmanship

The user who is carrying out the assembly is responsible for creating electrical circuits that will overcome all risks that may arise due to misuse during start, stop, emergency stop and maintenance.

It is necessary to check the compatibility of voltage and frequency. Operations should be carried out only by knowledgeable and authorised staff. In case air usage is required via pneumatic connections, the user should assemble a system to meet the requirements given on the technical information section.

The electrical earthing of the product must be proper, safety warnings should be clean and readable and all operations should be according to EN 60204-1:2018 standard.

Before each operation, always ensure that the power is disconnected before commencing. It is of vital important that power on/off button has to be manage by a qualified person to prevent uncontrolled opening and closing.

Make sure that all moving parts are in absolute stop before ach operation.

Always ensure that the dust inside the machine is completely settled.

Operators must use the following protection equipments during the maintenance and cleaning of the machine;

- Antistatic protective clothing
- Protective Hemlets
- Antistatic cut-proof gloves

- Safety masks
- Antistatic protective shoes

After assembly, check that all operations are properly and fully completed, all bolts are tightened, all warning labels, barriers and safety accessories are proper.

Do not start operation if the product is not complete and fully mounted. Do not interrupt externally during operation. Never approach while the units are operating. Never let tools, hand or head to approach to the operating zone during operation.

In case modifications are done without written consent of the producer, no responsibility will be assumed by the producer in case of damages and their consequences.

The product may display different wear and results according to material used and working conditions. Therefore the user is required to develop practices other than those given in this catalogue.

During the practice of below maintenance notes, situations that may result in harm to humans or machines or which prevent the product from working may occur. All inspections and maintenance must be done when product is in safe position.

Maintenance staff must be fully qualified. Tools for lifting and stabilizing must be used. No humans must be present during lifting and carrying operations.

It is important to use original parts or parts that have the required specifications.

It is possible that problems may occur and the product may be declared out of warranty in case maintenance work is carried out without full compliance to this maintenance guideline.

## 2.2 ASSEMBLY

Please consult to assembly instructions, which can be found inside of the each product package.

Carefully follow all technical, safety and worker health instructions during the assembly and the operation of the unit.

For right terminal connections of the unit, please double check voltage, frequency, local regulations and procedures.

Disconnect from all mains before opening the unit.

Start up the unit only when the cover is closed.

Provide protection for relay contacts and output transistors to protect the device against spikes with inductive loads.

A voltage-disconnecting switch must be provided near the device.

In the case of inexperienced handling or handling malpractice, the electric safety of the device cannot be guaranteed.

In the case of a defect, the distribution voltage must automatically be cut off by a protective switch so as to protect the user of the device from indirect contact with dangerous electric tensions.

All field wirings must have insulation suitable for at least 250VAC. The temperature rating must be at least 90°C.

Protect the power of the device by means of a fuse. The device body has to be earthed to avoid static charges. This is particularly important in pneumatic conveying applications or with non-metallic containers.

Close the cover when all connections are completed and supply the power. Always check the voltage with a voltmeter.

All electrical connections must be made according to the given connection diagram: make sure the cable is sealed tightly inside the cable gland.

Make sure the electrical connections is made properly and tightly. Setting on the assembled unit is not recommended.

Start the flange assembly as first step. Ensure that the filter flange is welded parallel to the place where the filter is used (silo, on bunker, etc.).

Locate the seal between flange and the filter and assemble the filter by the bolts and nuts supplied with the filter.

Complete the necessary connections for air. Ensure the air pressure is in the range of 4.5-5 bars and the air is dry. Connect the control board, apply to electronic control board notes in 2.4.

### 2.2.1 ASSEMBLY OF FAN ON FILTER

The filter is removed from the wooden packaging. The screws that connect the filter to the palette are not removed, the filter is left on the palette.

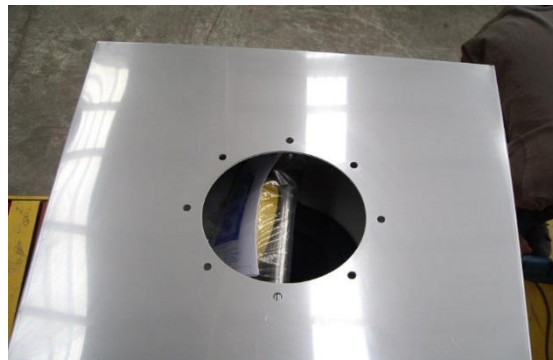

The fan suction hose connection flange is bolted onto the hole left for fan suction on the top cover. Sealing gasket is applied under the flange.

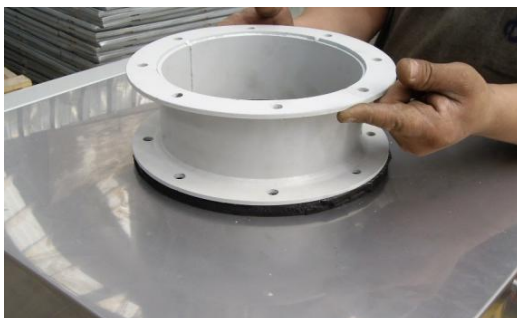

The fan outlet is turned in the appropriate direction and the fan is tightened to flange with the aid of a bolts and a nuts. Fan assembly is completed. Care and precaution should be exercised when the cover of the filter is opened. As the filter is not fixed on the ground, the weight of the fan can knock over the filter easily.

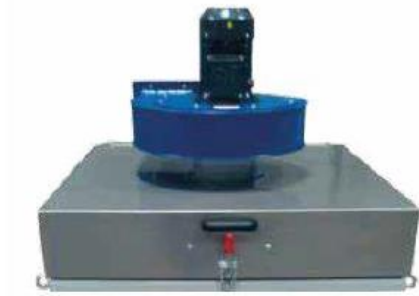

### 2.2.2 SIDE ASSEMBLY FAN ON SEPERATE FRAME

The filter is removed from the wooden packaging. The filter is mounted on the lower flange to be fixed in advance to the system to be applied.

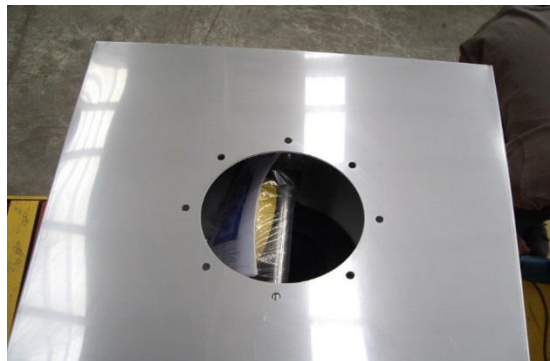

The fan suction hose connection flange is bolted onto the hole left for fan suction on the top cover. Sealing gasket is applied under the flange.

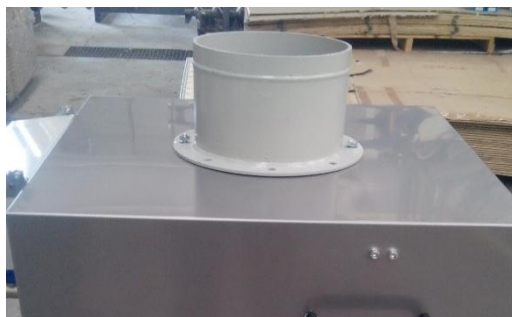

The foot fan outlet is turned in the appropriate direction and fixed to a suitable place near the filter. The suction hose is mounted on the filter flange and the suction opening on the fan is tightened with steel clamp.



### 2.2.3 ASSEMBLY OF EMISSION SAMPLING KIT

Emission sampling kit for AIRFILL Filters is available as an option. The vertical exhaust discharge pipe must be supplied by the user.



Close one of the two clean air outlets on the filter element plate with a blind flange.

Fit the part with the cylindrical pipe outlet to the other one.



You can mount the user-supplied vertical exhaust discharge pipe on the pipe shown below.



### 2.3 START UP

Install the unit properly to the system. Make sure the electrical connection is made properly and tightly. Setting on the assembled unit is not recommended.

Before starting up the unit, make sure that no foreign bodies have entered during assembly if they have, remove them.

Ensure the pressurized air is dried by convenient air dryer and no oil shall be permitted. Check the electrical connections. Run the unit unloaded (idle) for a while.

Ensure that all energy air pressurized lines are properly connected and power selections are correct. Energize the electronic control board and check the valves are operative and sequencing is OK by listening to click sound on valves.

The pulse intervals are set to 40-45 seconds, it should not be changed.

The compressor airline must be dried and conditioned with a regulator and it should be reduce to 4.5 bars pressure with the manometer regulator filter set. The water accumulate in the water tank should be cleaned frequently.

Make sure that solenoid valves are working properly. Check the cleaning cycle intervals and the pause time.

In case of any control and maintenance make sure energy and pressurized air is off and the tank is clean.

Overfilling should not be allowed. Filling should not be allowed after the maximum level warning.

After the silobas filling is completed, the remaining amount of the silobas must not be cleaned with excessive air. (silobas should not be inflated and opened suddenly)

Run the machine for max 2-3 minutes to observe and listen. Re-check the product and observe if heating has occurred on any component and/or abnormal noise, vibration occurs.

**IMPORTANT:** All connections should be undertaken by qualified electrical personnel only. Occupational safety and employee health requirements must be complied with. Before carrying out any operation on the motor, make sure that the electrical supply is disconnected. The constructor declines to take any responsibility for any damages to property or persons, arising from poor electrical workmanship.

**Air inlet**  
1/4" Ri: 10mm

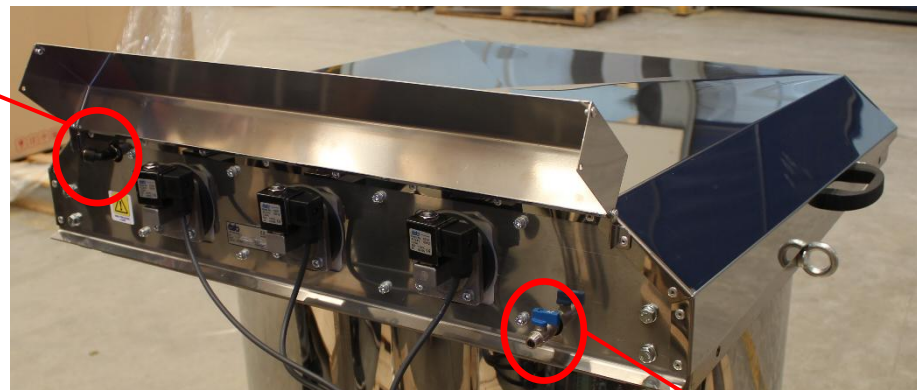

**Water discharge**

## 2.4 FILTER CONTROL BOARD

The Board is inside, 160x60x60mm sealed waterproof, IP65 protection class box, and 110VAC, 220VAC 50/60 Hz or 24VDC voltage can be applied.



Allways shut off valtage, before and during operation on the card.

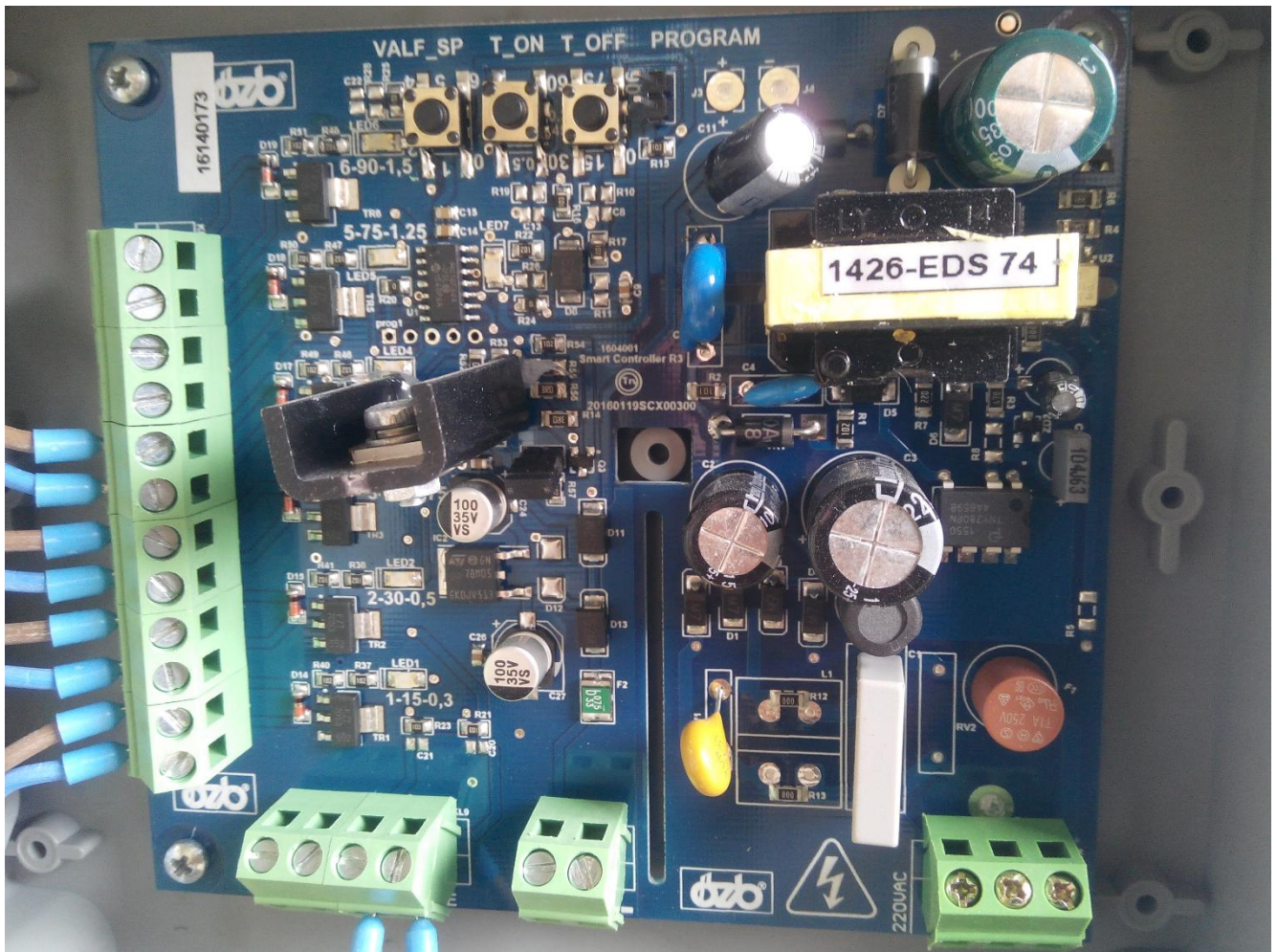

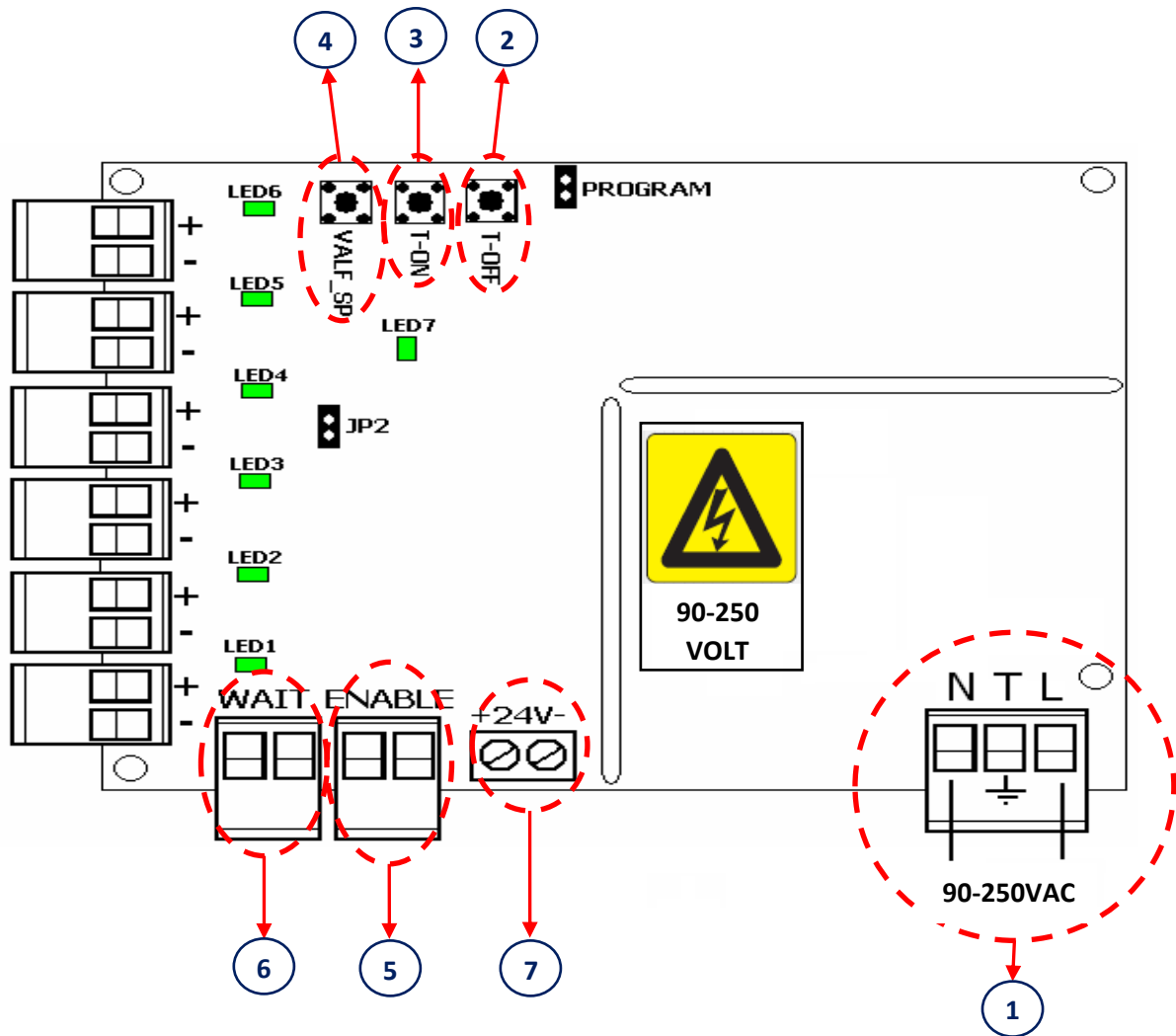

Figure - 1

- 1- NTL Feed input (90-250VAC / 50-60Hz)
- 2- T\_OFF Waiting Time
- 3- T\_ON Operating time
- 4- VALF\_SP Adjustment of valve quantity
- 5- ENABLE
- 6- WAIT
- 7- DC

N: Neutral  
T: Earth  
L: Line

### 2.4.1 NTL FEEDING INPUT (90-250VAC / 50-60Hz)

90-250V feed input of device. Device is fed with 90-250V, can be seen the lighting of LED7 on board.

When Jumper is plugged to JP1; programmable mode,  
 When jumper is plugged to JP2; valves' operating mode.

**NEVER:** JP1 and JP2 must not be plugged at the same time.

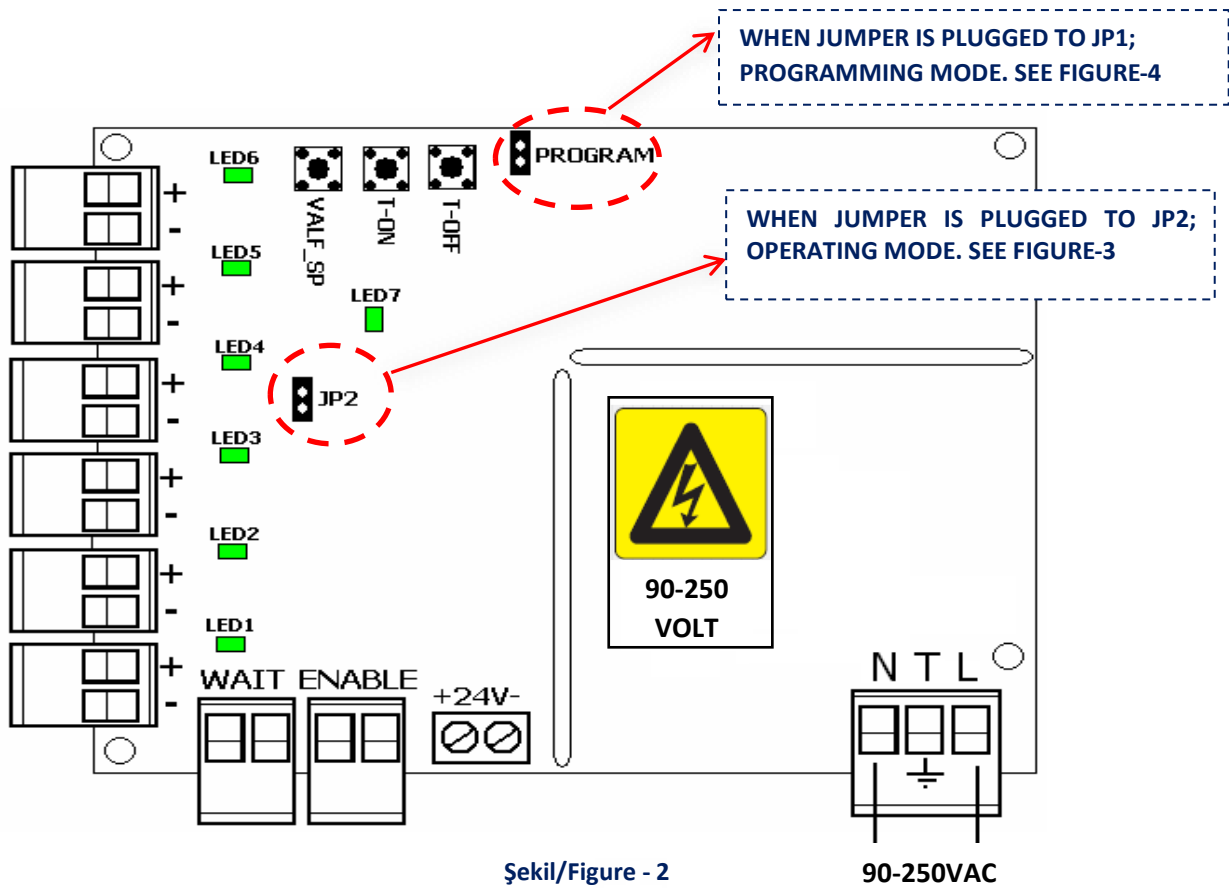

### 2.4.1.1 OPERATING MODE

To make the filter card ready to work, the "JUMPER" must be set as shown in the red circle on the photograph. See Figure-3.

### 2.4.1.2 PROGRAMMABLE MODE

To program filter card and set valve number, stand by and working time, the "JUMPER" must be set as shown in red circle "PROGRAMME" on the photographs. See Figure-4

After settings, the jumper has to be put on work mode. See Figure-3

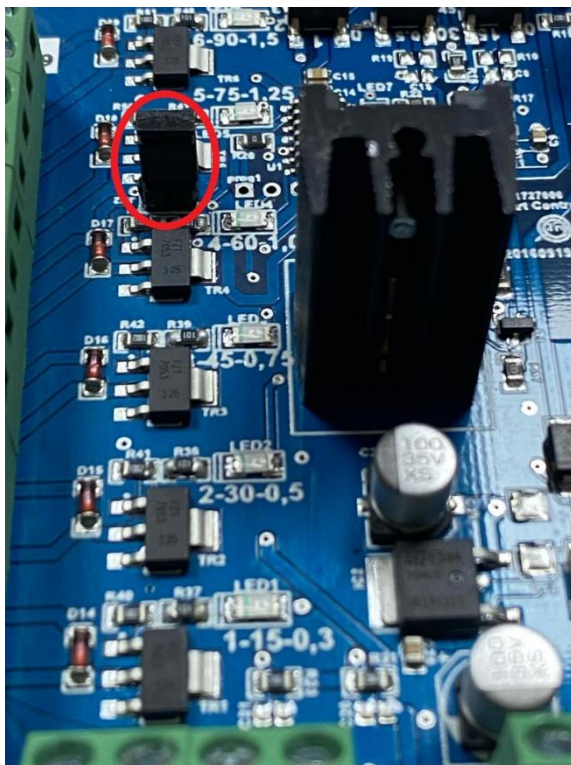

Figure - 3

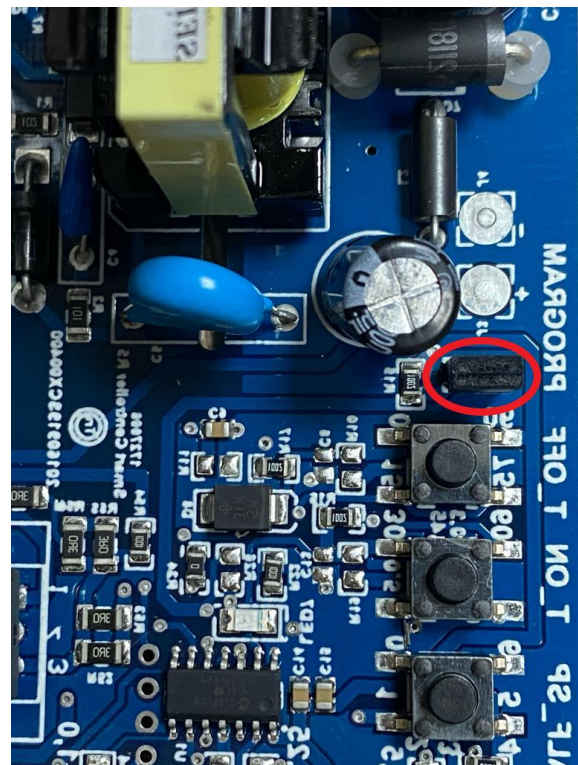

Figure - 4

### 2.4.2 T-OFF WAITING TIME

Stand by time is the time interval of valve's which will be energied turn by turn. This time interval can be adjusted for 0.5-90sec.

Factory settings is 45 seconds.

With every short pushes to the T\_OFF switch, time interval increases 5 sec. and LED1 and LED7 wink.

With long push to the T\_OFF switch, time interval increases 15 sec.

In 15sec stand by time, LED1 is lighting continuously.

In 30sec stand by time, LED1,2 are lighting continuously.

In 45sec stand by time, LED1,2,3 are lighting continuously.

In 60sec stand by time, LED1,2,3,4 are lighting continuously.

In 75sec stand by time, LED1,2,3,4,5 are lighting continuously.

In 90sec stand by time, LED1,2,3,4,5,6 are lighting continuously.

The media under high frequency emissions might cause deviation of  $\pm 10$  seconds.

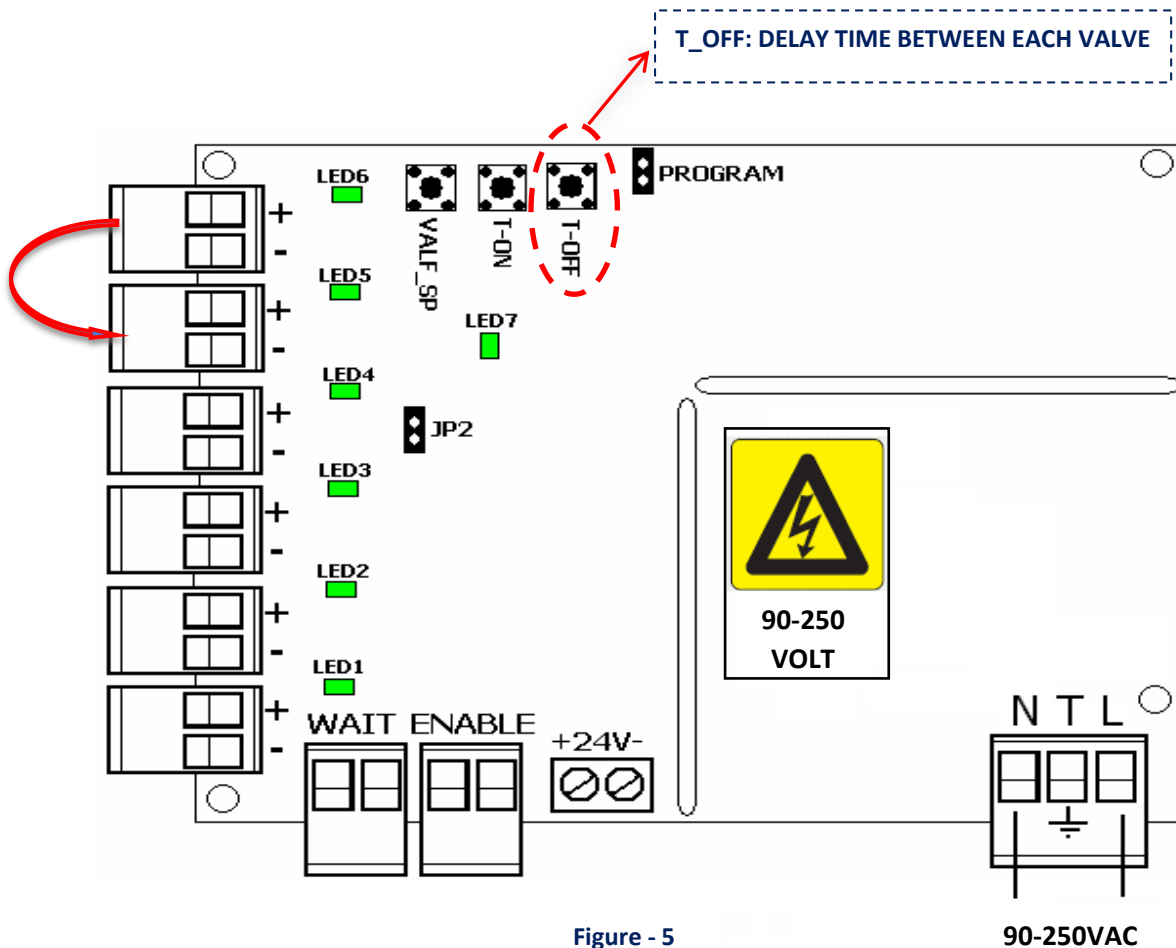

Figure - 5

### 2.4.3 T-ON OPERATION TIME

Operation time is the interval when the outputs of valve's are energized. This time interval can be adjusted for 0.3-1.5 sec.

Factory settings is 0.3 seconds.

If any LED is not lighting, time interval is 0.2 sec

If LED1 is lighting, time interval is 0.30 sec

If LED2 is lighting, time interval is 0.50 sec

If LED3 is lighting, time interval is 0.75 sec

If LED4 is lighting, time interval is 1.00 sec

If LED5 is lighting, time interval is 1.25 sec

If LED6 is lighting, time interval is 1.50 sec

The media under high frequency emissions might cause deviation of + or – up to 10 seconds.

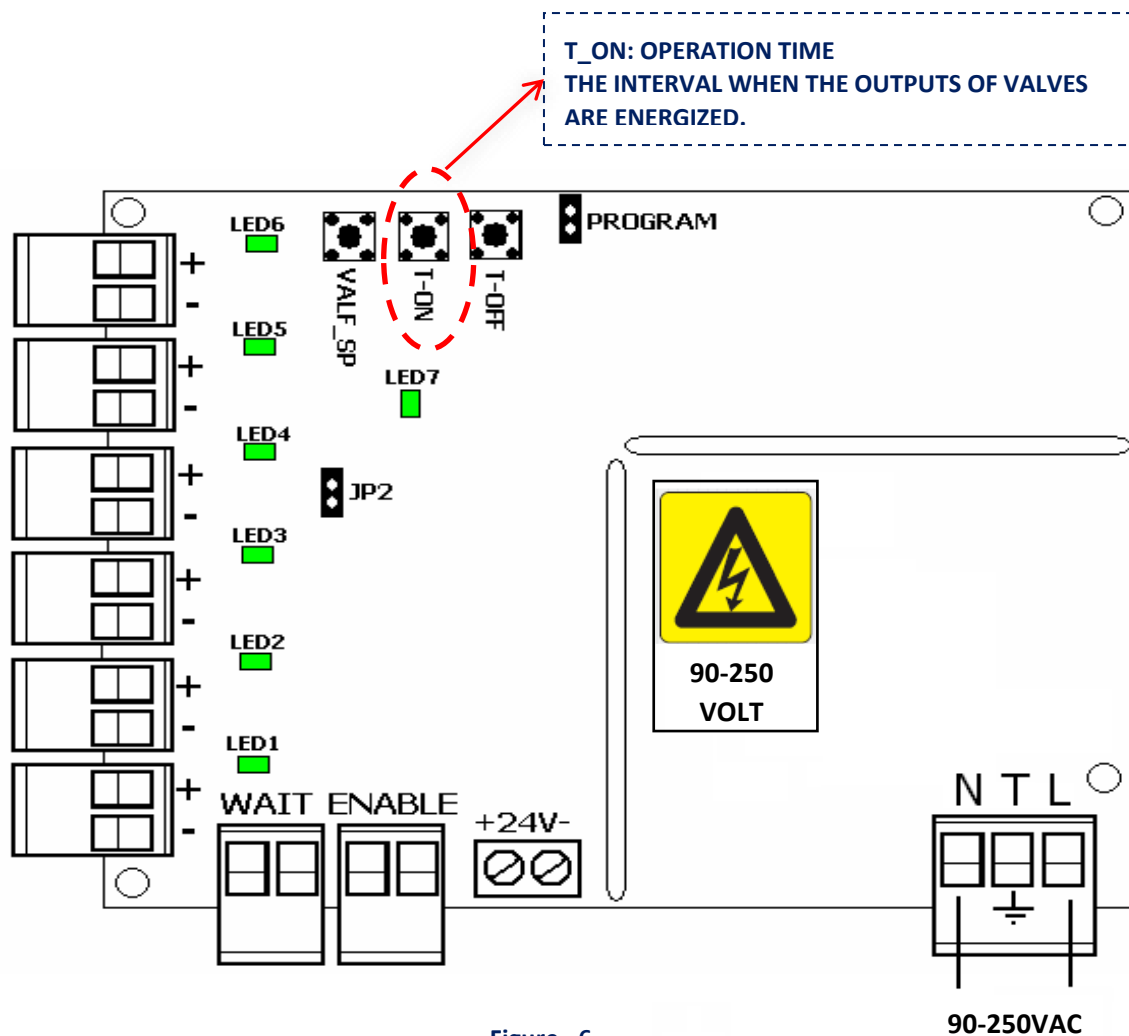

Figure - 6

### 2.4.4 VALF\_SP ADJUSTMENT OF VALVE QUANTITY

Adjustment of quantity of valves assigns the system's operation with how many valves.

If LED1 is lighting: 1 Valve

If LED2 is lighting: 2 Valves

If LED3 is lighting: 3 Valves

If LED4 is lighting: 4 Valves

If LED5 is lighting: 5 Valves

If LED6 is lighting: 6 Valves

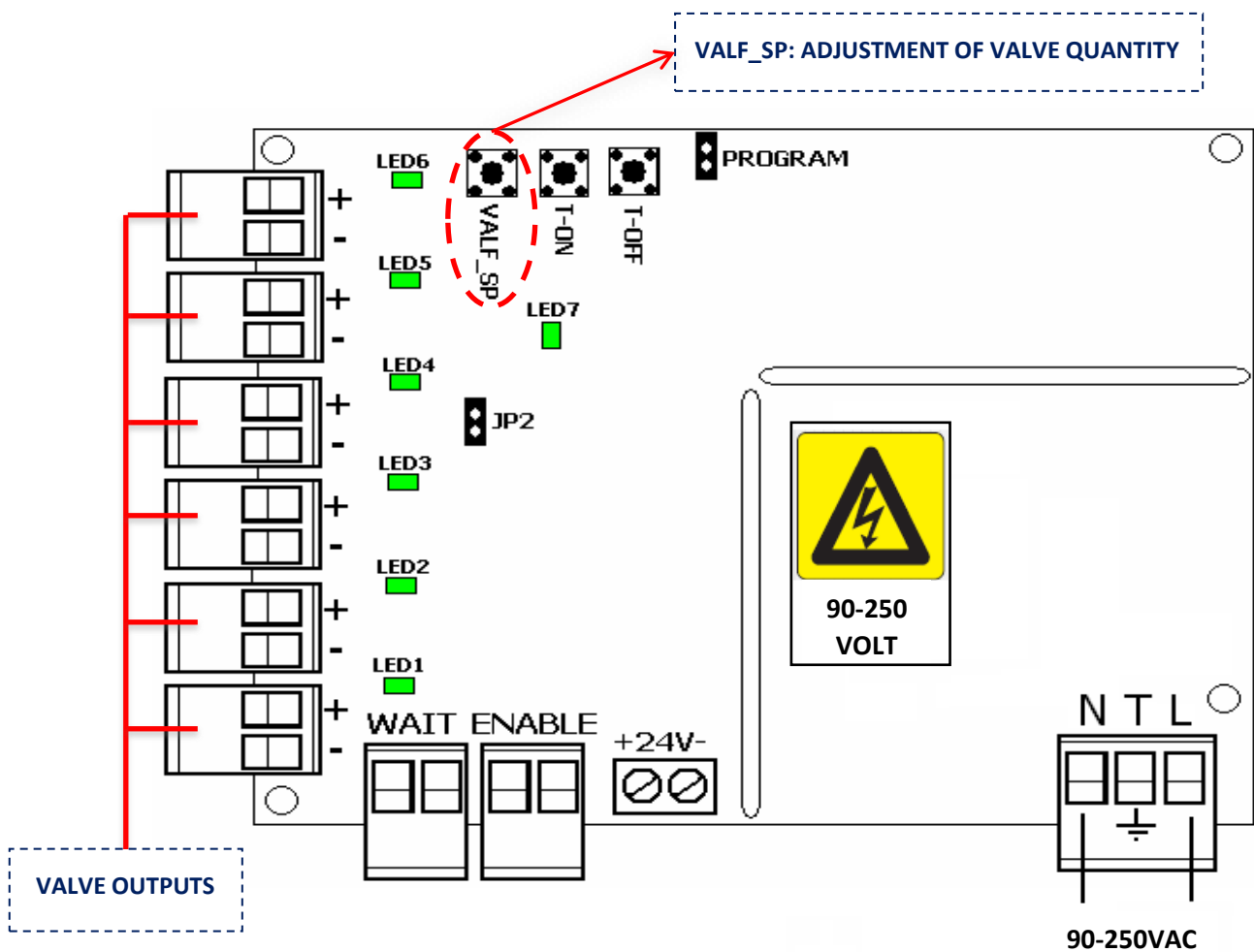

Figure - 7

#### **2.4.5 ENABLE**

An external contact enables the board.

#### **2.4.6 WAIT**

If stand by is required while the system operates, operation of valves can be stopped by a short circuit due to the external contact. Valves will continue to operate after an open circuit.

#### **2.4.7 DC**

+24VDC feeding connector

### **OPERATION**

Please apply the following procedures to run the board properly:

- a. Adjust number of valves.  
(VALF\_SP)
- b. Set the operation time.  
(T\_ON)
- c. Set the wAiting time.  
(T\_OFF)
- d. Apply an external contact on ENABLE sockets to activate the board.



The external contact shall have no energy.

If any pause is needed during operation please activate “WAIT” socket by means of external contact.

When the external contact is deactivated the system continues to run from the point it was interrupted.

## 2.5 VALVE HEATER CARD (OPTIONAL)

The valve heater is used for heating valves that will operate at low temperatures.

Input voltage (standard): 110/230VAC

Output power: 108W



Heater Card

Filter Control Board

### 2.5.1 FILTER TIMER HEATER CONNECTION

Below diagram shows the heater connections.

With switch on the thermostat, heater must be set to minimum working temperature to cut the energy at required temperature.

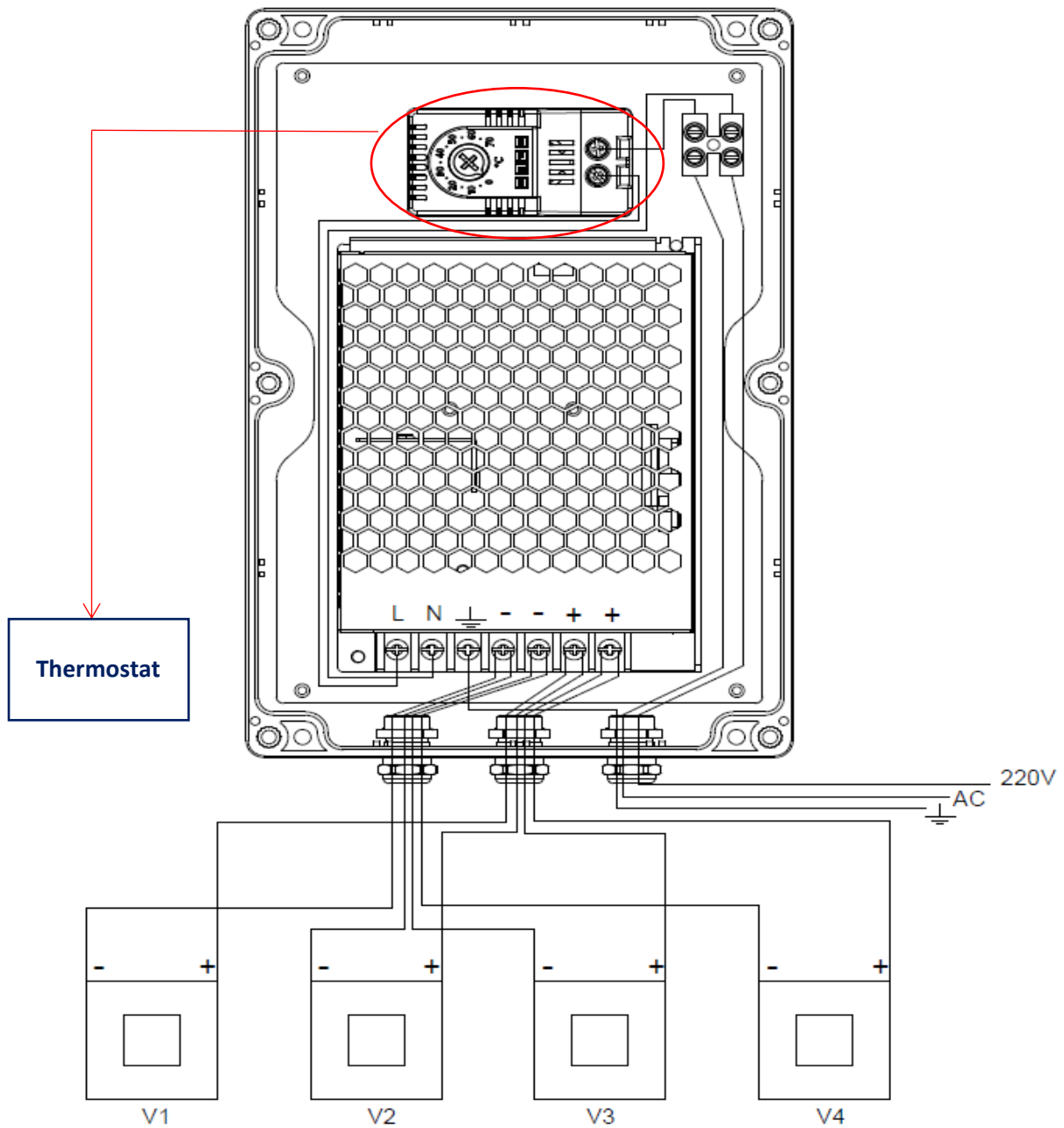

Set the thermostat to the request temperature.

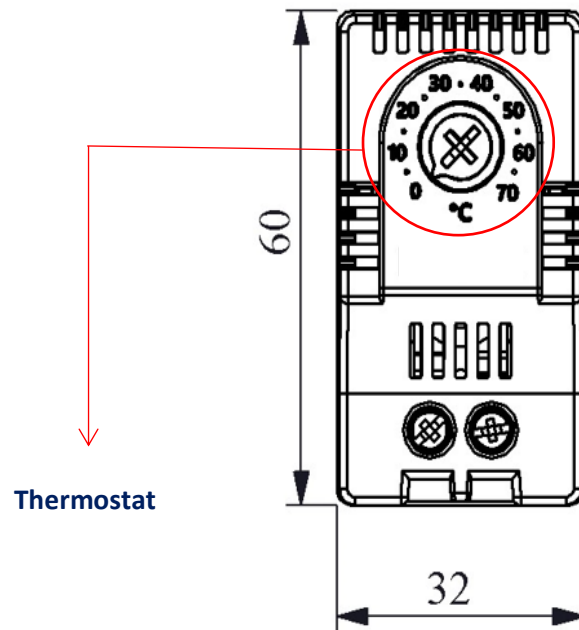

## 2.6 MAINTENANCE

Before maintenance procedures, all power lines must be disconnected.

Prior to each action, check that the energy lines are cut. It is vitally important to take precautions in order to prevent the on/off button of the power supply from being operated without authorization or control.

In case modifications are done without written consent of the producer, no responsibility will be assumed by the producer in case of damages and their consequences.

The product may display different wear and results according to material used and working conditions. Therefore the user is required to develop practices other than those given in this manual.

During the practice of below maintenance notes, situations that may result in harm to humans or machines or which prevent the product from working may occur. All inspections and maintenance must be done when product is in safe position.

Supply and use safety equipment and tools that may be required for worker safety.

Maintenance staff must be fully qualified. Tools for lifting and stabilizing must be used. No humans must be present during lifting and carrying operations.

It is important to use original parts or parts that have the required specifications.

It is possible that problems may occur and the product may be declared out of warranty in case maintenance work is carried out without full compliance to this maintenance guideline.

Before each shift:

Check the unit visually.

Check that the warning labels on the machine are present and in good condition.

Check the electric motor cable and connections.

Check all the bolts and nuts present and they are tightened.

Daily maintenance:

Check the unit visually.

Check the cables and pneumatic lines, correct any defect.

Check if the filter pulse function is operating.

Open the discharge valve of the filter air tank to discharge accumulated water.

Weekly maintenance:

Open the top cover to check the clean part of the filter plate for dust.

Minor dust accumulation is normal, clean with a soft brush and/or compressed air.

Check the coils and fixing bolts.

Check the cable and sockets.

Monthly maintenance:

In addition to daily controls, turn off energy and the air supply.

Discharge the air in the tank and keep the tank release valve open during maintenance.

Open the cover.

Disassemble the distributor and place it safely.

Disassemble the filtering elements, check for anomalies such as damage, wear or tear.

Check the surface for dirt. Use plastic or wood without sharp edges to clean sticking material.

Do not perform hard or penetrative actions.

If necessary, clean by pressurized air or wash with water.

After drying, grease the lower platform and around the ring by using lubricants other than soap and petrol based products.

Clean the filter plate surface and replace or reassemble the filtering element.

Assemble the distributor and reassemble the filter by repeating the above steps in reverse order.

Ensure that the unit is functional.

## 2.7 LUBRICATION

There is not any parts required lubrication.

## 2.8 REPLACEMENT OF COMPONENTS

If you should require spares for your unit, please contact with producer and it is necessary to inform all datas such as serial number, type etc. which are written on the machine's plate. Do not use non-original parts.

### 2.8.1 REPLACEMENT OF CARTRIDGE

Filter with fan fixed to the frame.  
Release the front lock.

Open the cover by gently lifting up.  
Open completely and lock it.



Lock the cover stopper by pin.  
Loose the nuts of filtering by elements.



Take out the filtering elements.  
Apply for re-assembly in reverse.



**If the filter element is of the type that can be replaced from the inspection hatch;**

Open the inspection cover.  
Remove the filter elements by turning.



## 2.9 DEMOLITION

At the end of the working life of the unit, demolish it according to the following recommendations: plastic parts consigning them to the authorized collection centres.

## 2.10 DEFINING PROBLEMS AND TROUBLE SHOOTING

Below are some guidelines regarding problems that may occur during the operation of the product.

Energy supply and pressurized air shall be available and condensed water to be discharged.

Turn on the electronic card, if red and green lights are not on, check the fuse at energy inlet. Check that coil of the valve is intact and functional.

During all controls, energy must be off, pressurized air lines empty and tank completely discharged of pressurized air.

The pilot group shall be disassembled. (Make sure that the cylinder and spring inside the pilot to not change position). Ensure that the cylinder can move easily inside the pilot and is free from rust, grease, dust and residue. It is important that the 1,5mm hole in the pilot slot is not blocked, if so clean.

Open the top cover of the jet pulse valve with an Allen wrench and lift the cover without dropping the bolts.

Take out the diaphragm plate. Ensure that the channel on the top cover and holes on the pipe are not blocked, if so clean. Ensure that the diaphragm is free from dirt, residue, tear and similar defects.

Ensure that the valve lower body outlet and inlets are clean.

Ensure that the inlet and outlet holes of the distributor are open and functional. Check that distributor outlets are at the center of the filtering elements.

Repeat all above steps in reverse order and for each valve to reassemble the filter and re-connect energy and pressurized air.

If the filter does not start, apply to producer with a detailed report of what you have done and the final status of the filter.

If filtering elements get blocked frequently, in addition to other controls, check the silo filling pipe outlet. It shall be perpendicular and downwards. If it is horizontal the emission is excessive, correct it.

### Hints:

If everything seems normal but the safety valve frequently is open then;

Filtering elements may be blocked.

Filtering elements may be wet.

Filtering elements may be oily.

Cleaning air pressure may be low.

Cleaning pulse cycle may be less than 10 seconds and the second pulse occurs before tank is full.

No energy.

No cleaning air.

PROBLEM	POSSIBLE CAUSE-SOLUTION
Filtering elements over blocked	Check compressed air supply and pressure level Check electronic card and correct adjustment Check solenoid valve&coils
Dust and lumps under the cap and body on the filter	Check if filtering elements are damaged Check the seals on body Check if filtering elements & frame are properly located



[www.ozb.com.tr](http://www.ozb.com.tr)

# 3.

## SPARE PARTS CATALOGUE

If you should require spares for your unit, please contact with producer and it is necessary to inform all datas such as serial number, type etc. which are written on the machine's plate. Do not use non-original parts.

DUST COLLECTOR CONTROL BOARD	
Code	
FRSJ71213100	

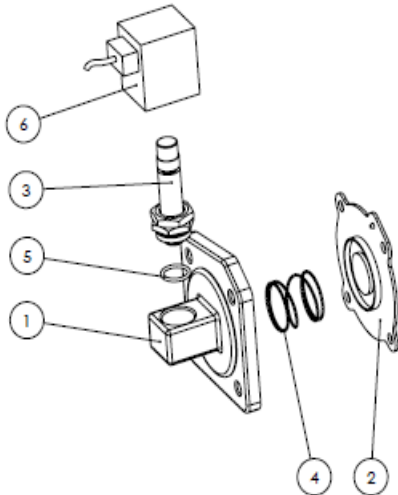
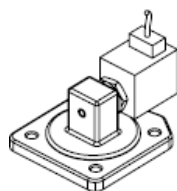
VALVE AND COIL			
Code	Description	#	
FRSJ71224000	Valve Cover	1	
FRSJ71222010	Diaphragm	2	
FRSJ71223000	Pilot M20x1	3	
N09-0852117	Spring	4	
N10-0156018	Oring	5	
FRSJ71222040	Coil and Socket 24VAC-DC	6	
FRSJ71222000	Complete Set	1 + 2 + 3 + 4 + 5 + 6	

FILTER ELEMENTS			
Code	Suitable Filter	Diameter	Height
FE.C.S.156.0900.ST Cartridge	FP1MK156STV020 FP2MK156STV040	Ø156mm 6.14"	900mm 35.43"
FE.C.S.218.0700.ST (FESK218ST) Cartridge	FP1SK218STV030 FP2SK218STV060	Ø218mm 8.58"	700mm 27.56"
FE.C.S.218.1000.ST (FELK218ST) Cartridge	FP1LK218STV043 FP2LK218STV090 POLYFILL 90	Ø218 8.58"	1,000mm 39.37"
FE.E.S.490.1000.ST Elliptical Bag	FP1SE490STV010 FP1SE490STH010 FP2SE490STH020	490mm 19.29"	1,000mm 39.37"
FE.E.S.490.1500.ST Elliptical Bag	FP1LE490STV015 FP2LE490STV030 FP1LE490STH015 FP2LE490STH030 FP2SE490STV020	490mm 19.29"	1,500mm 59.06"
FE.E.S.490.2000.ST Elliptical Bag	FP1LL490STV020 FP2LL490STV040	490mm 19.29"	2,000mm 78.74"



FILTER ELEMENT CAGE		
Code	Suitable Filter	Material
FK.E.S.490.1000.1	FP1SE490STV010 FP1SE490STH010 FP2SE490STH020	Galvanized
FK.E.S.490.1500.1	FP1LE490STV015 FP2LE490STV030 FP1LE490STH015 FP2LE490STH030 FP2SE490STV020	

FK.E.S.490.2000.1

FP1LL490STV020  
FP2LL490STV040